

Skylight Permits for Single Family and Duplex Dwellings

The installation of skylights requires at least a Building Permit and may require other permits: In some townhouses and planned communities, a Planning Permit may also be required. If vents are to be relocated, a Plumbing Permit or Mechanical Permit may be required. If lights are being relocated or added, then an Electrical Permit is also required as well as associated electrical inspection.

APPLICABLE FEES

A plan check fee and permit fee will be assessed for the review and issuance of all skylight permits. Refer to the [Fee Schedule](#) for current fee amounts.

Permits and inspections

- Help keep your property safe
- Help assure the quality of your remodeling investment
- Are required by law

We'll answer your questions about permits.

Contestaremos sus preguntas referente a permisos en Español.

Chúng tôi sẽ trả lời thắc mắc về giấy phép của quý vị bằng tiếng Việt.

San José Permit Center

San José City Hall
200 E. Santa Clara St.
San José, CA 95113
408-535-3555

<ul style="list-style-type: none"> • A roof plan is required 	<p>The roof plan must:</p> <ul style="list-style-type: none"> • Show the location and size of each skylight; note if they are fixed or operating • Operating skylights are to be located: <ul style="list-style-type: none"> □ 10 feet from or 3 feet below a plumbing vent □ 4 feet from or 1 foot below a gas flue □ 3 feet from and 1 foot below an air exhaust duct If unable to meet these location criteria, it must be a fixed type. • Townhouses - Skylight roof openings in townhouses must not be located in the 5-foot wrapback area next to a fire-rated party wall. • List the slope of the roof and the size and spacing of the rafters. • Provide a framing detail with roof and ceiling plan and cross-section of the openings.
<ul style="list-style-type: none"> • Glazing requirements 	<ul style="list-style-type: none"> • The skylights must be dual glazed and have a minimum U-value of .75. • Plastic skylights must comply with UBC Chapter 26 and the ICC Listing number provided. • Glass skylights must comply with UBC Chapter 24, which details laminated, wired, heat-strengthened, and tempered glazing in skylights as well as screening requirements. The type of glazing must be listed by an approved agency.
<ul style="list-style-type: none"> • Framing requirements 	<p>Conventional framing must comply with the following:</p> <ul style="list-style-type: none"> • Roof slope must be 3:12 or greater. • Rafters must comply with allowable spans. • If existing roof spans were met by purlins being installed, support struts that extend to bearing walls must be re-installed at the mid span of the rafters and trimmers. • Double trimmers and headers when the span of the header exceeds 4 feet. • The ends of header rafters more than 6 feet long shall be supported by adequate framing anchors (Simpson A35/eq) or joist hangers (LU26/btr). • Truss roofs: If trusses are cut, the plans must be stamped by an engineer, with calculations and details of any repairs provided. • If conventional framing is installed around the opening, engineering is not required. • Curb requirements: <ul style="list-style-type: none"> <i>Plastic skylights</i> - Mount on curbs at least 4 inches above the surface of the roof. Curbs may be omitted on ICC Listing self-flashing skylights when installed on roofs with a minimum slope of 3:12. <i>Glass skylights</i> - Mount on curbs at least 4 inches above the roof plane when installed on roofs that are less than a 12:12 slope • Skylights and curb are to be flashed and securely fastened per the manufacturer's recommendations.

INSPECTION PROCEDURES

- A. At least two inspections are required to inspect rough frame, insulation, flashings, any vent relocations, and the smoke alarms are upgraded. Locate smoke alarms per UBC 310.9.1.4 in each sleeping area or room, also halls, top of stairs, and raised ceilings or shafts off bedroom halls that are over 24 inches high.
- B. For each inspection, the Permit, City-Stamped Drawings, and ICCB/ICBO Report (if applicable) must be on site, and the inspector must be provided access to the work. Note: Inspectors do not carry ladders.
- C. Residential skylight sheetrock nail typically does not require inspection, but do NOT use greenboard on ceilings.
- D. The property owner or licensed contractor can request an inspection by calling (408) 277-4541 or by visiting <http://www.sjpermits.org/permits>

SKYLIGHT DETAIL

Plan View:

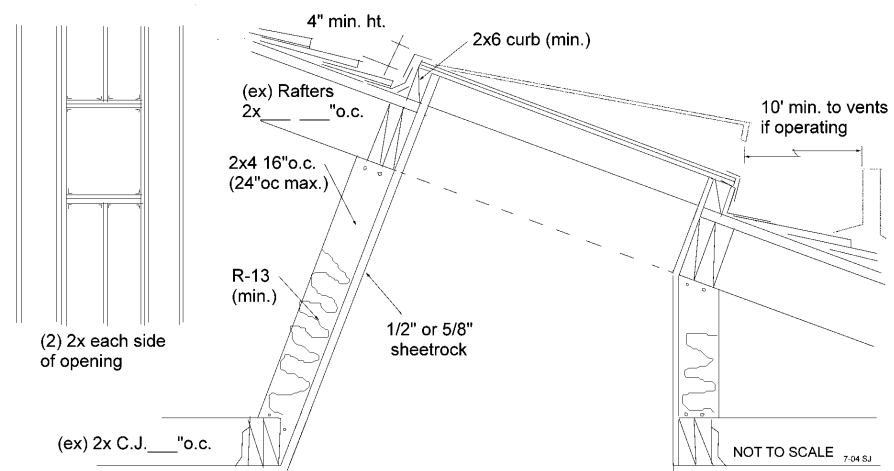

*Manufacturer's installation specifications and ICBO# to be available for frame inspection.

*Truss Roof: See attached engineering calculations regarding any cut truss chords.

*To field verify rafters and any purlins are adequately braced to bearing walls.

Code Sections:

UBC 2409.4: 4" min. above roof (or per manufacturer's specifications).

UBC 2320.12.5: Double trimmer and headers at opening when span exceeds 4' and use hangers if it exceeds 6'.

UPC 906.2: Plumbing vents shall terminate at least 10' from or 3' above any opening.

UMC 806.6: Gas and exhaust vents shall terminate at least 4' from or 1' above any openable skylight.