

*ILLUSTRATIVE PLANNING DIAGRAM – FOR REFERENCE ONLY*

## ROOFTOP HVAC – EXAMPLE DRAWINGS

**1. Photos** – show rooftop parapet, screens on roof and general location on roof

**2. Roof Plan**

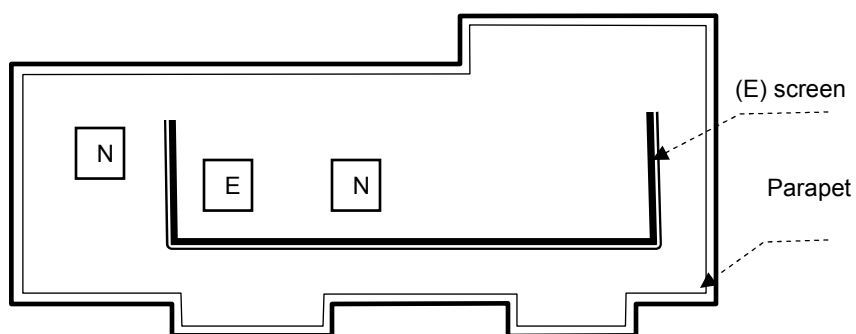

**3. HVAC/AC Brochure/specification sheet**

- A/C height
- A/C size
- A/C lbs
- Sleeper height

**4. Site Plan** – show adjacent building especially in a complex

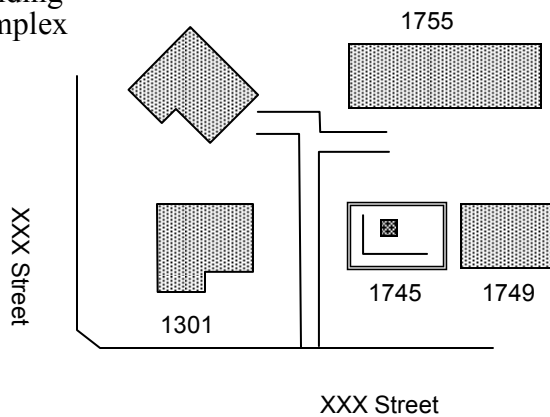

SAN JOSE PLANNING DEPARTMENT  
PLANNING REVIEW FOR  
ROOFTOP MECHANICAL EQUIPMENT

PERMIT ADJUSTMENT NOT REQUIRED

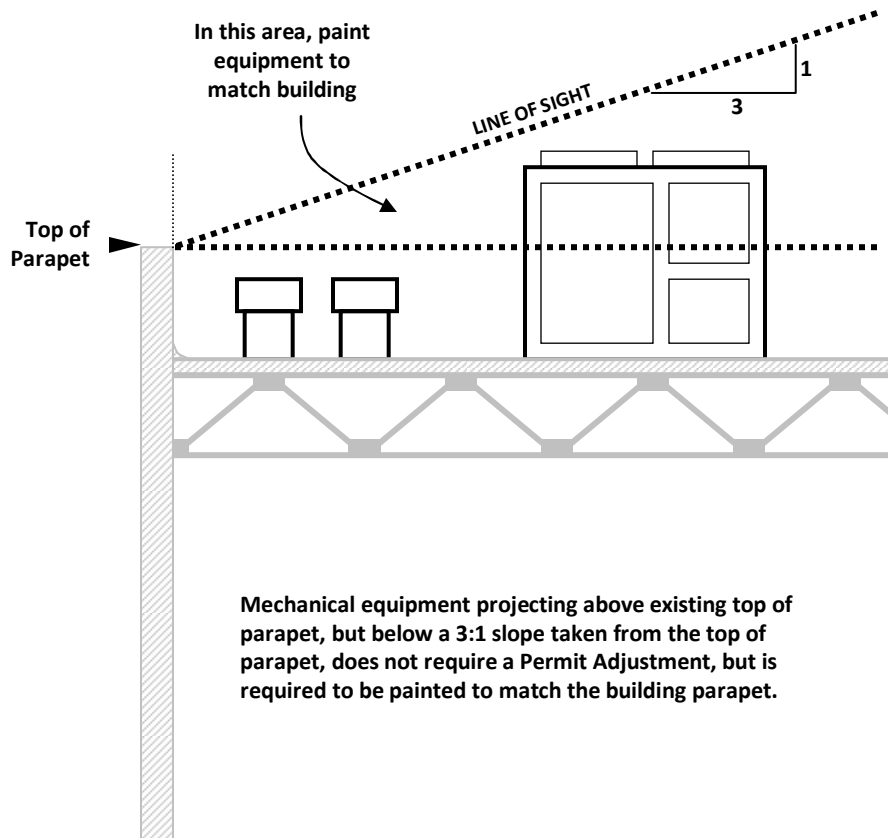

PERMIT ADJUSTMENT REQUIRED

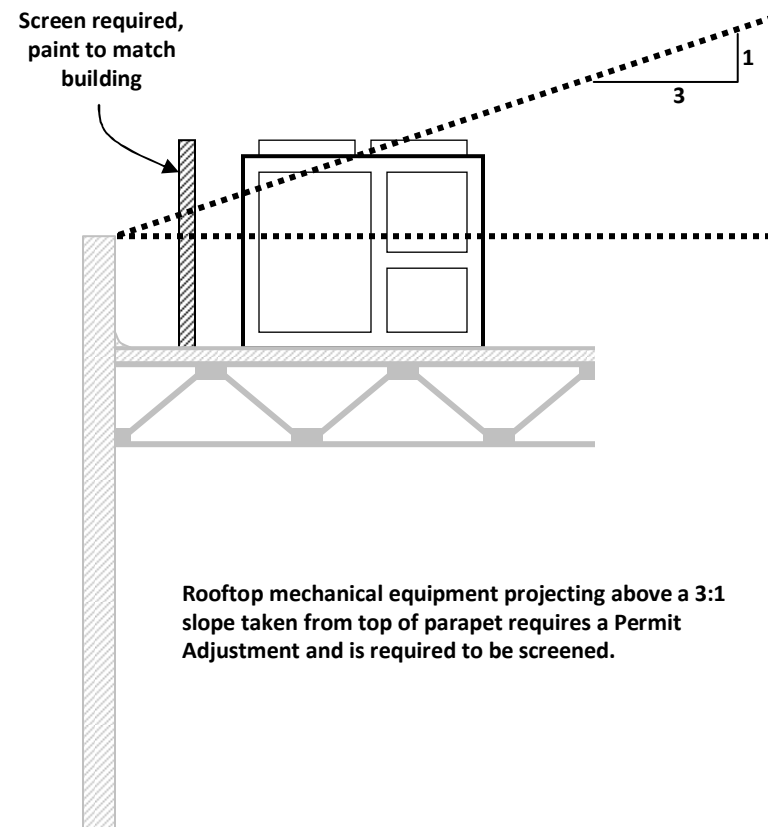

ILLUSTRATIVE DIAGRAM – FOR REFERENCE ONLY

PK: 3/13/13 Loc: Phonecounter/FAQs/Illustrative Diagrams